

1. General description

Silicon Carbide Schottky diode in a TO220F-2L plastic package, designed for high frequency switched-mode power supplies.

2. Features and benefits

- Highly stable switching performance
- High forward surge capability I_{FSM}
- Extremely fast reverse recovery time
- Superior in efficiency to Silicon Diode alternatives
- Reduced losses in associated MOSFET
- Reduced EMI
- Reduced cooling requirements
- RoHS compliant
- Insulated package rated at 2500V RMS

3. Applications

- Power factor correction
- Telecom / Server SMPS
- UPS
- PV inverter
- PC Silverbox
- LED / OLED TV
- Motor Drives

4. Quick reference data

Table 1. Quick reference data

Symbol	Parameter	Conditions	Values			Unit
Absolute maximum rating						
V_{RRM}	repetitive peak reverse voltage		650			V
$I_{F(AV)}$	average forward current	$\delta = 0.5$; square-wave pulse; $T_n \leq 77\text{ }^\circ\text{C}$; Fig. 1 ; Fig. 2 ; Fig. 3	6			A
Symbol	Parameter	Conditions	Min	Typ	Max	Unit
Static characteristics						
V_F	forward voltage	$I_F = 6\text{ A}$; $T_j = 25\text{ }^\circ\text{C}$; Fig. 5	-	1.5	1.7	V
		$I_F = 6\text{ A}$; $T_j = 150\text{ }^\circ\text{C}$; Fig. 5	-	1.8	2.1	V

5. Pinning information

Table 2. Pinning information

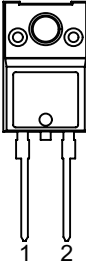
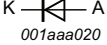
Pin	Symbol	Description	Simplified outline	Graphic symbol
1	K	cathode		
2	A	anode		
mb	n.c.	mounting base; isolated		

6. Ordering information

Table 3. Ordering information

Type number	Package name	Orderable part number	Packing method	Small packing quantity	Package version	Package issue date
GKTSC06650X	TO220F-2L	GKTSC06650X6Q	Tube	50	TO220FN-2L	05-July-2015

7. Marking

Table 4. Marking codes

Type number	Marking codes
GKTSC06650X	GKTSC 06650X

8. Limiting values

Table 5. Limiting values

In accordance with the Absolute Maximum Rating System (IEC 60134).

Symbol	Parameter	Conditions	Values	Unit
V_{RRM}	repetitive peak reverse voltage		650	V
V_{RWM}	crest working reverse voltage		650	V
V_R	reverse voltage	DC	650	V
$I_{F(AV)}$	average forward current	$\delta = 0.5$; square-wave pulse; $T_h \leq 77^\circ\text{C}$; Fig. 1 ; Fig. 2 ; Fig. 3	6	A
I_{FRM}	repetitive peak forward current	$\delta = 0.5$; $t_p = 25\ \mu\text{s}$; $T_h \leq 77^\circ\text{C}$; square-wave pulse	12	A
I_{FSM}	non-repetitive peak forward current	$t_p = 10\ \text{ms}$; $T_{j(\text{init})} = 25^\circ\text{C}$; sine-wave pulse	36	A
		$t_p = 10\ \mu\text{s}$; $T_{j(\text{init})} = 25^\circ\text{C}$; square-wave pulse	310	A
I^2t	I^2t for fusing	$t_p = 10\ \text{ms}$; $T_{j(\text{init})} = 25^\circ\text{C}$; sine-wave pulse	6.48	A^2s
T_{stg}	storage temperature		-55 to 175	$^\circ\text{C}$
T_j	junction temperature		175	$^\circ\text{C}$

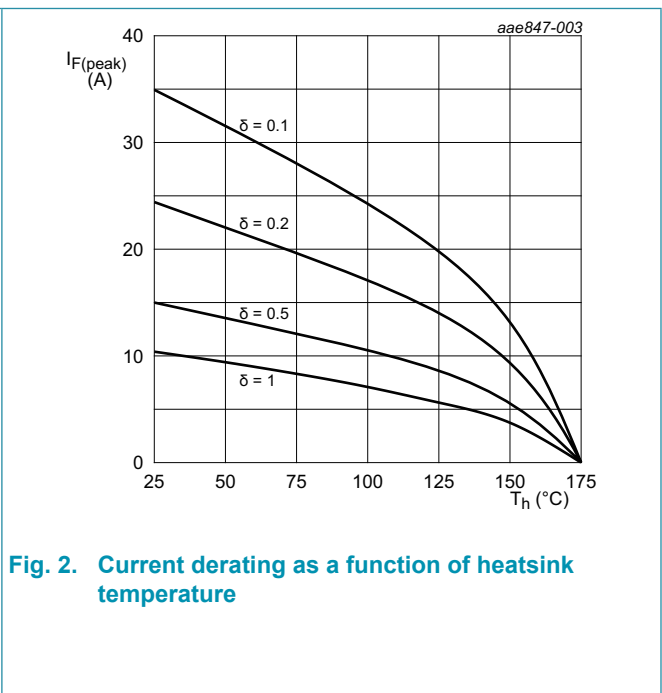
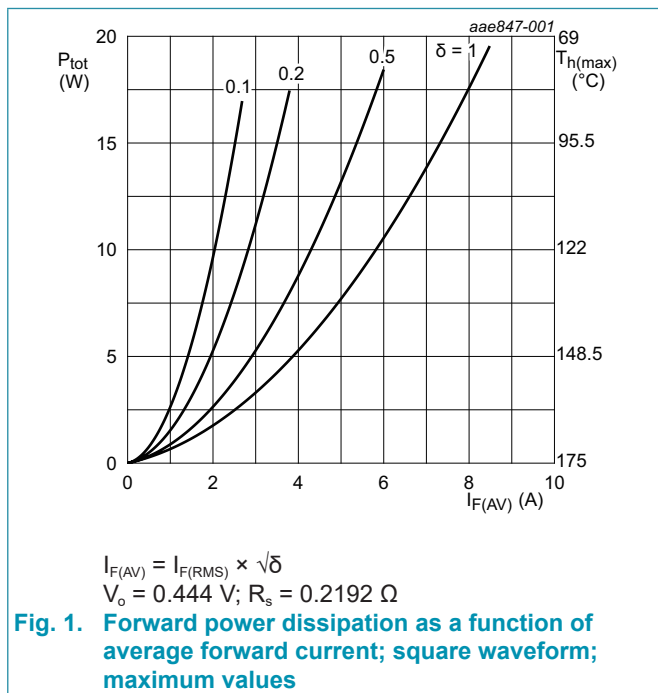

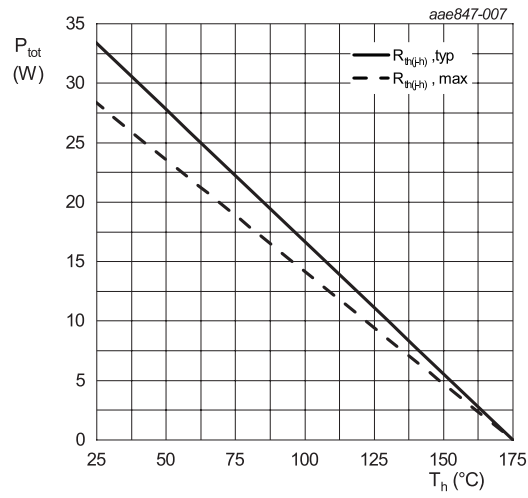

Fig. 3. Total power dissipation as a function of heatsink temperature

9. Thermal characteristics

Table 6. Thermal characteristics

Symbol	Parameter	Conditions	Min	Typ	Max	Unit
$R_{th(j-h)}$	thermal resistance from junction to heatsink	with heatsink compound; Fig. 4	-	4.5	5.3	K/W
$R_{th(j-a)}$	thermal resistance from junction to ambient free air	in free air	-	55	-	K/W

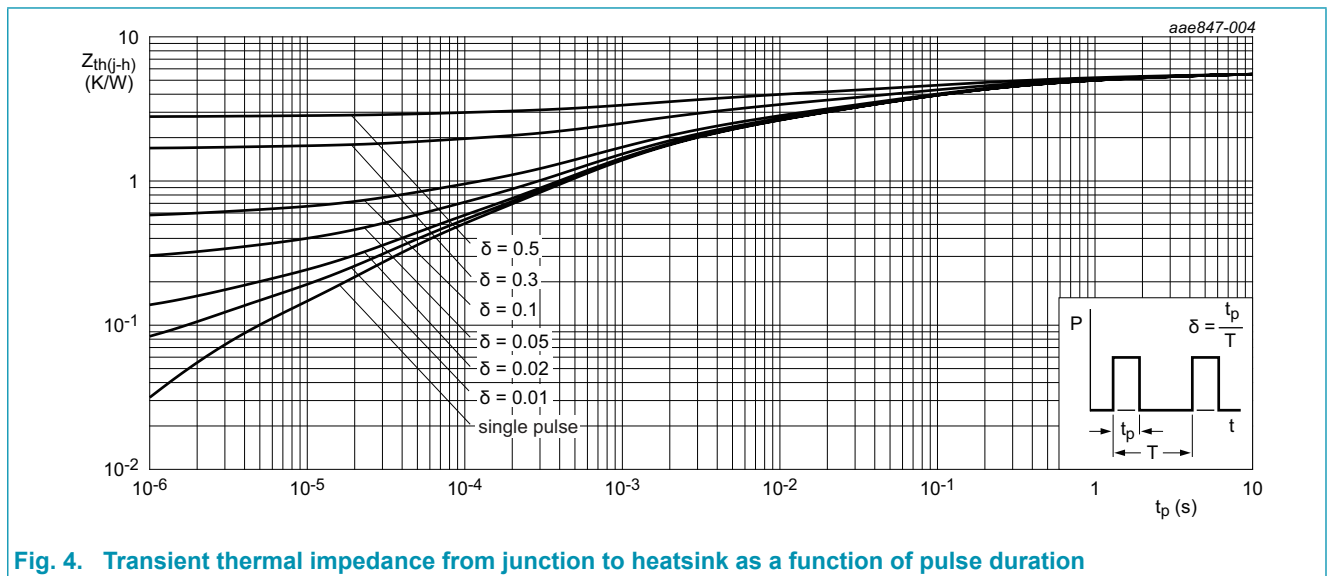

Fig. 4. Transient thermal impedance from junction to heatsink as a function of pulse duration

10. Isolation characteristics

Table 7. Isolation characteristics

Symbol	Parameter	Conditions	Min	Typ	Max	Unit
$V_{isol(RMS)}$	RMS isolation voltage	from all terminals to external heatsink; sinusoidal waveform; clean and dust free; $50 \text{ Hz} \leq f \leq 60 \text{ Hz}$; $T_h = 25 \text{ }^\circ\text{C}$; $RH \leq 65 \%$	-	-	2500	V

11. Characteristics

Table 8. Characteristics

Symbol	Parameter	Conditions	Min	Typ	Max	Unit
Static characteristics						
V_F	forward voltage	$I_F = 6 \text{ A}; T_j = 25 \text{ }^\circ\text{C}; \text{ Fig. 5}$	-	1.5	1.7	V
		$I_F = 6 \text{ A}; T_j = 150 \text{ }^\circ\text{C}; \text{ Fig. 5}$	-	1.8	2.1	V
I_R	reverse current	$V_R = 650 \text{ V}; T_j = 25 \text{ }^\circ\text{C}; \text{ Fig. 6}$	-	-	40	μA
		$V_R = 650 \text{ V}; T_j = 150 \text{ }^\circ\text{C}; \text{ Fig. 6}$	-	-	160	μA
Dynamic characteristics						
Q_r	recovered charge	$I_F = 6 \text{ A}; V_R = 400 \text{ V}; di_F/dt = 500 \text{ A}/\mu\text{s}; T_j = 25 \text{ }^\circ\text{C}; \text{ Fig. 7}$	-	9	-	nC
C_d	diode capacitance	$f = 1 \text{ MHz}; V_R = 1 \text{ V}; T_j = 25 \text{ }^\circ\text{C}$	-	190	-	pF
		$f = 1 \text{ MHz}; V_R = 300 \text{ V}; T_j = 25 \text{ }^\circ\text{C}$	-	30	-	pF
		$f = 1 \text{ MHz}; V_R = 600 \text{ V}; T_j = 25 \text{ }^\circ\text{C}$	-	29	-	pF
E_{as}	non-repetitive avalanche energy	$I_R = 4.25 \text{ A}; T_{j(\text{init})} = 25 \text{ }^\circ\text{C}; L = 5 \text{ mH}$	45	-	-	mJ

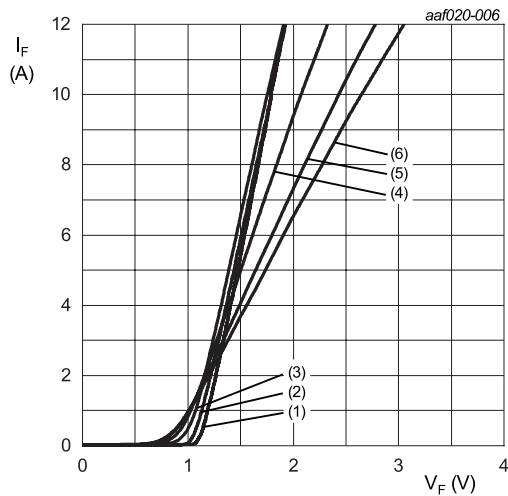

$V_o = 0.444 \text{ V}; R_s = 0.2192 \text{ } \Omega$
 (1) $T_j = -55 \text{ }^\circ\text{C}$; typical values
 (2) $T_j = 0 \text{ }^\circ\text{C}$; typical values
 (3) $T_j = 25 \text{ }^\circ\text{C}$; typical values
 (4) $T_j = 100 \text{ }^\circ\text{C}$; typical values
 (5) $T_j = 150 \text{ }^\circ\text{C}$; typical values
 (6) $T_j = 175 \text{ }^\circ\text{C}$; typical values

Fig. 5. Forward current as a function of forward voltage; typical values

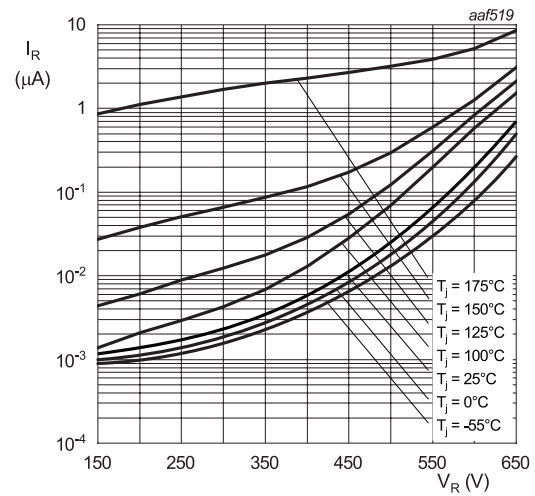

Fig. 6. Reverse leakage current as a function of reverse voltage; typical value

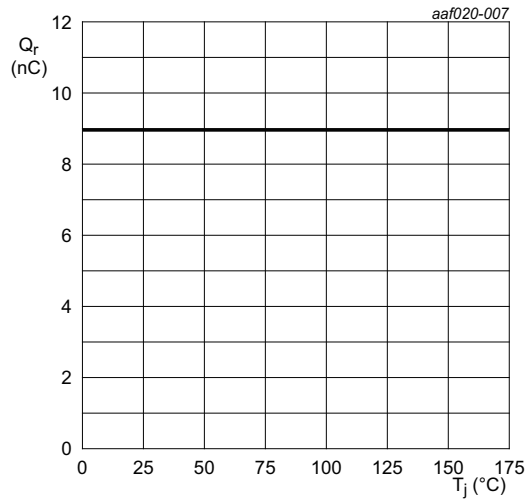
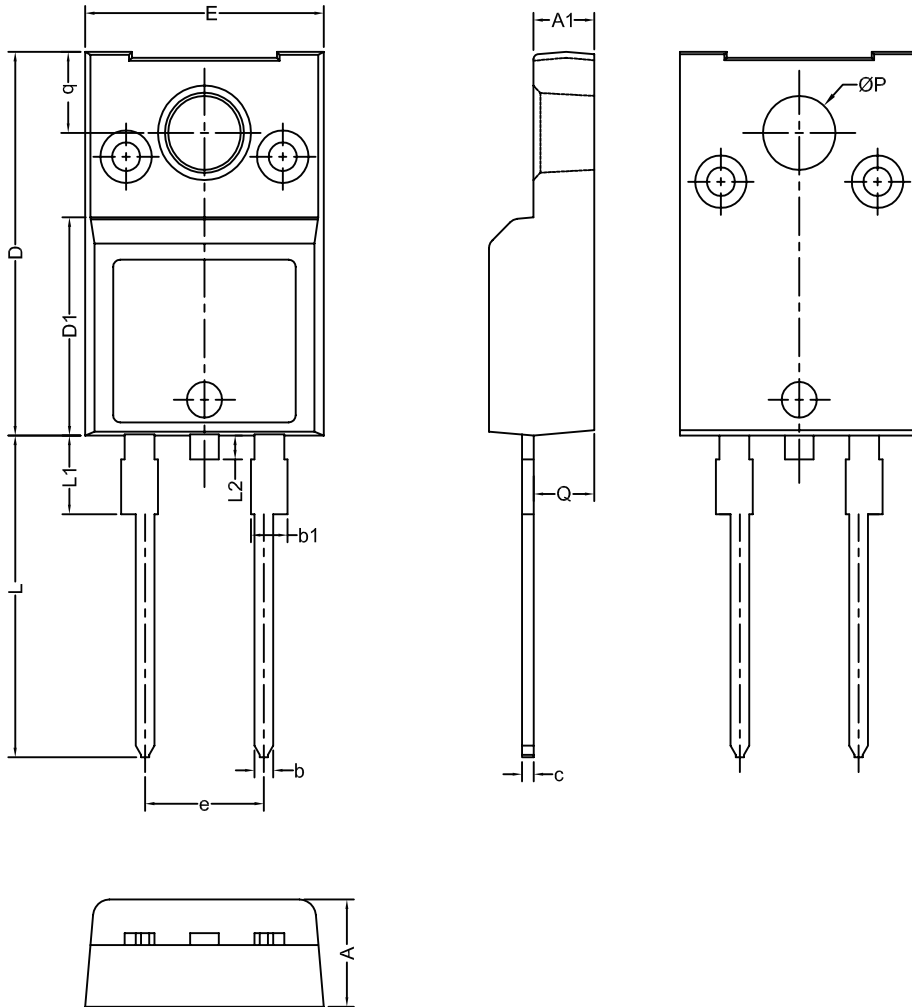

Fig. 7. Recovered charge as a function of junction temperature

12. Package outline

Plastic single-ended through-hole package; isolated heatsink mounted; 1 mounting hole; 2-lead TO-220F TO220F-2L



Unit	A	A1	b	b1	c	D	D1	e	E	L	L1	L2	P	q	Q
min	4.35	2.40	0.76	1.22	0.46	15.95	9.00	5.08	10.05	13.15	3.15	0.50	2.95	3.40	2.30
max	4.65	2.80	0.89	1.60	0.59	16.25	9.30	5.08 (typ)	10.35	13.85	3.45	1.00	3.25	3.40 (typ)	2.80

OUTLINE VERSION	REFERENCES			EUROPEAN PROJECTION	ISSUE DATE
	IEC	JEDEC	EIAJ		
TO220F-2L		-			

IMPORTANT NOTICE – PLEASE READ CAREFULLY

SZGKT Microelectronics NV and its subsidiaries reserve the right to make changes, corrections, enhancements, modifications, and improvements to SZGKT.