

### 1. General description

Dual Silicon Carbide Schottky diode in a 3-lead TO247 plastic package, designed for high frequency switched-mode power supplies.

### 2. Features and benefits

- Highly stable switching performance
- High forward surge capability  $I_{FSM}$
- Extremely fast reverse recovery time
- Superior in efficiency to Silicon Diode alternatives
- Reduced losses in associated MOSFET
- Reduced EMI
- Reduced cooling requirements
- RoHS compliant
- High junction operating temperature capability ( $T_{j(max)} = 175\text{ °C}$ )

### 3. Applications

- Power factor correction
- Telecom / Server SMPS
- UPS
- PV inverter
- PC Silverbox
- LED / OLED TV
- Motor Drives

### 4. Quick reference data

Table 1. Quick reference data

Symbol	Parameter	Conditions	Values			Unit
<b>Absolute maximum rating</b>						
$V_{RRM}$	repetitive peak reverse voltage		1200			V
$I_{O(AV)}$	limiting average output current	$\delta = 0.5$ ; $T_{mb} \leq 147\text{ °C}$ ; square-wave pulse; both diodes conducting; <a href="#">Fig. 1</a> ; <a href="#">Fig. 2</a> ; <a href="#">Fig. 3</a> ; <a href="#">Fig. 4</a>	10			A
$T_j$	junction temperature		175			°C
Symbol	Parameter	Conditions	Min	Typ	Max	Unit
<b>Static characteristics</b>						
$V_F$	forward voltage	$I_F = 5\text{ A}$ ; $T_j = 25\text{ °C}$ ; per diode; <a href="#">Fig. 6</a>	-	1.4	1.6	V
		$I_F = 5\text{ A}$ ; $T_j = 150\text{ °C}$ ; per diode; <a href="#">Fig. 6</a>	-	1.85	2.3	V
		$I_F = 5\text{ A}$ ; $T_j = 175\text{ °C}$ ; per diode; <a href="#">Fig. 6</a>	-	2	2.6	V
<b>Dynamic characteristics</b>						
$Q_r$	recovered charge	$I_F = 5\text{ A}$ ; $V_R = 400\text{ V}$ ; $di_F/dt = 500\text{ A}/\mu\text{s}$ ; $T_j = 25\text{ °C}$ ; per diode; <a href="#">Fig. 8</a>	-	12	-	nC

## 5. Pinning information

Table 2. Pinning information

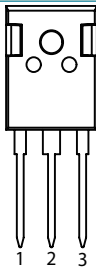
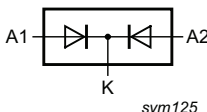
Pin	Symbol	Description	Simplified outline	Graphic symbol
1	A1	anode		 sym125
2	K	cathode		
3	A2	anode		
mb	K	mounting base; connected to cathode		

## 6. Ordering information

Table 3. Ordering information

Type number	Package name	Orderable part number	Packing method	Small packing quantity	Package version	Package issue date
GKTSC101200CW	TO247	GKTSC101200CWQ	Tube	30	TO247N	05-Jul-2015

## 7. Marking

Table 4. Marking codes

Type number	Marking codes
GKTSC101200CW	GKTSC101200CW

### 8. Limiting values

**Table 5. Limiting values**

In accordance with the Absolute Maximum Rating System (IEC 60134).

Symbol	Parameter	Conditions	Values	Unit
$V_{RRM}$	repetitive peak reverse voltage		1200	V
$V_{RWM}$	crest working reverse voltage		1200	V
$V_R$	reverse voltage	DC	1200	V
$I_{FRM}$	repetitive peak forward current	$\delta = 0.5$ ; $t_p = 25 \mu s$ ; $T_{mb} \leq 147^\circ C$ ; square-wave pulse; per diode	10	A
$I_{O(AV)}$	limiting average output current	$\delta = 0.5$ ; $T_{mb} \leq 144^\circ C$ ; square-wave pulse; both diodes conducting; <a href="#">Fig. 1</a> ; <a href="#">Fig. 2</a> ; <a href="#">Fig. 3</a> ; <a href="#">Fig. 4</a>	10	A
$I_{FSM}$	non-repetitive peak forward current	$t_p = 10 ms$ ; $T_{j(init)} = 25^\circ C$ ; sine-wave pulse; per diode	65	A
		$t_p = 10 \mu s$ ; $T_{j(init)} = 25^\circ C$ ; sine-wave pulse; per diode	525	A
$I^2t$	$I^2t$ for fusing	sine-wave pulse; $T_{j(init)} = 25^\circ C$ ; $t_p = 10 ms$ ; per diode	21	A <sup>2</sup> s
$T_{stg}$	storage temperature		-55 to 175	°C
$T_j$	junction temperature		175	°C

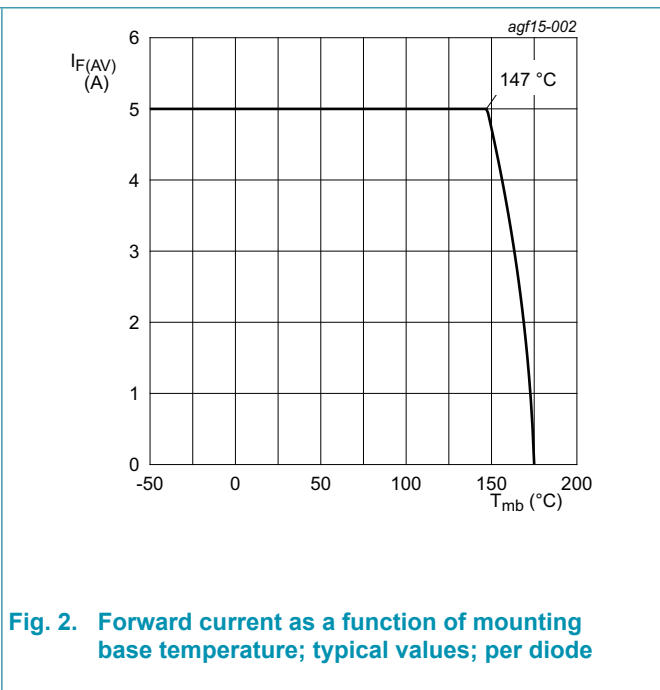
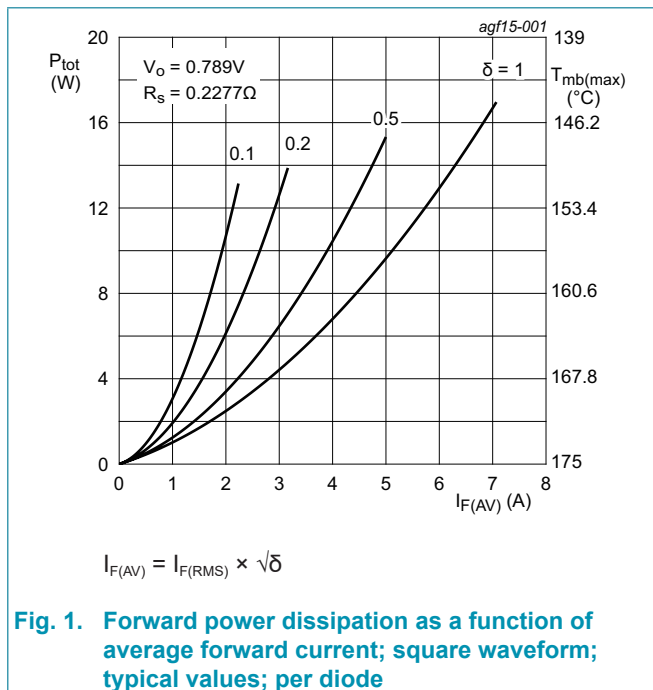

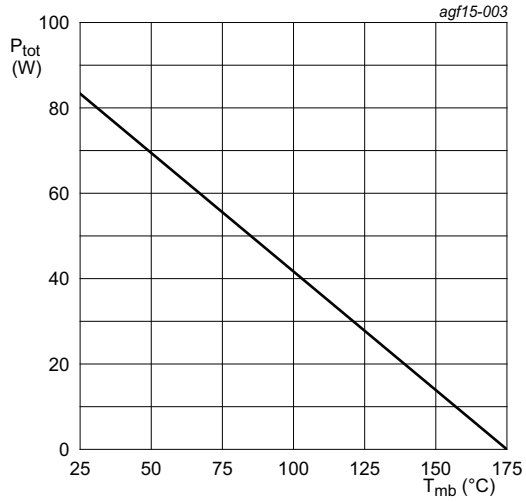

**Fig. 3. Total power dissipation as a function of mounting base temperature; per diode**

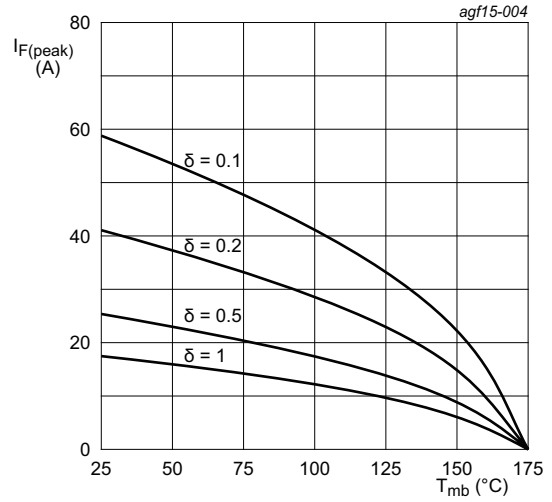
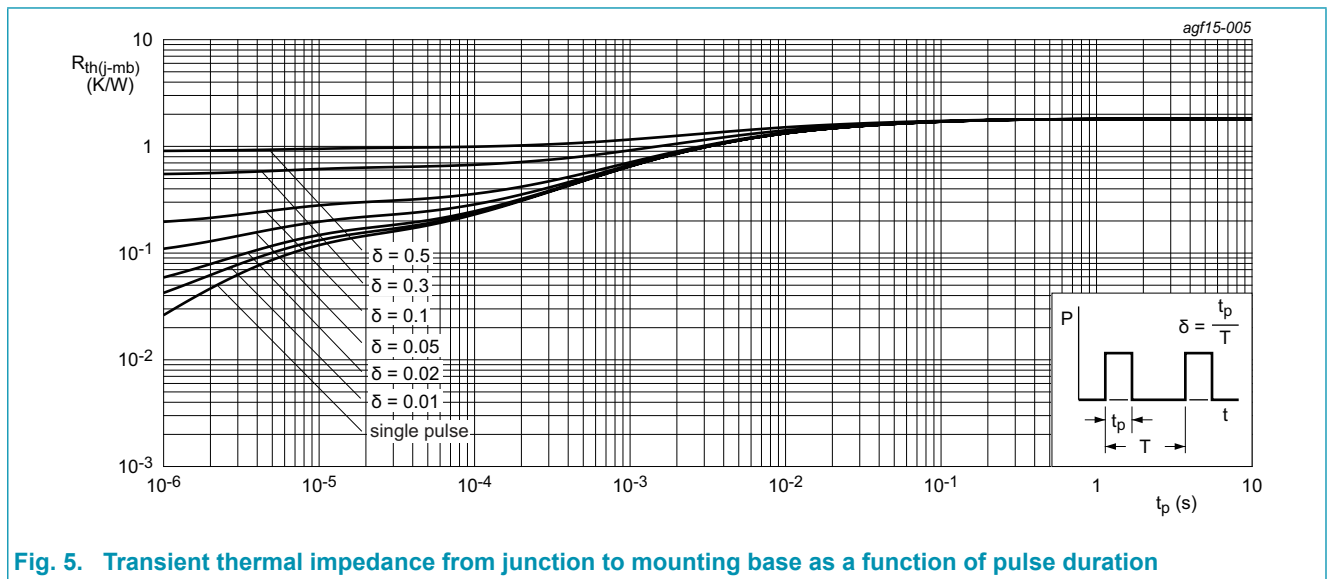

**Fig. 4. Current derating as a function of mounting base temperature; per diode**

**9. Thermal characteristics**

**Table 6. Thermal characteristics**

Symbol	Parameter	Conditions	Min	Typ	Max	Unit
$R_{th(j-mb)}$	thermal resistance from junction to mounting base	per diode; <a href="#">Fig. 5</a>	-	-	1.8	K/W
		both diodes conducting	-	-	1	K/W
$R_{th(j-a)}$	thermal resistance from junction to ambient free air	in free air	-	40	-	K/W

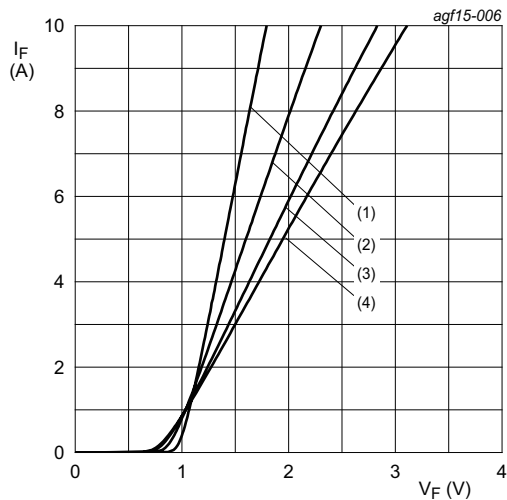

**Fig. 5. Transient thermal impedance from junction to mounting base as a function of pulse duration**

### 10. Characteristics

Table 7. Characteristics

Symbol	Parameter	Conditions	Min	Typ	Max	Unit
<b>Static characteristics</b>						
$V_F$	forward current	$I_F = 5 \text{ A}; T_j = 25 \text{ }^\circ\text{C};$ per diode; <a href="#">Fig. 6</a>	-	1.4	1.6	V
		$I_F = 5 \text{ A}; T_j = 150 \text{ }^\circ\text{C};$ per diode; <a href="#">Fig. 6</a>	-	1.85	2.3	V
		$I_F = 5 \text{ A}; T_j = 175 \text{ }^\circ\text{C};$ per diode; <a href="#">Fig. 6</a>	-	2	2.6	V
$I_R$	reverse current	$V_R = 1200 \text{ V}; T_j = 25 \text{ }^\circ\text{C};$ per diode; <a href="#">Fig. 7</a>	-	4	50	$\mu\text{A}$
		$V_R = 1200 \text{ V}; T_j = 175 \text{ }^\circ\text{C};$ per diode; <a href="#">Fig. 7</a>	-	150	-	$\mu\text{A}$
<b>Dynamic characteristics</b>						
$Q_r$	recovered charge	$I_F = 5 \text{ A}; V_R = 400 \text{ V}; dI_F/dt = 500 \text{ A}/\mu\text{s};$ $T_j = 25 \text{ }^\circ\text{C};$ per diode; <a href="#">Fig. 8</a>	-	12	-	nC
$C_d$	diode capacitance	$f = 1 \text{ MHz}; V_R = 1 \text{ V}; T_j = 25 \text{ }^\circ\text{C}$	-	250	-	pF
		$f = 1 \text{ MHz}; V_R = 400 \text{ V}; T_j = 25 \text{ }^\circ\text{C}$	-	24.5	-	pF
		$f = 1 \text{ MHz}; V_R = 800 \text{ V}; T_j = 25 \text{ }^\circ\text{C}$	-	22	-	pF



- (1)  $T_j = 25 \text{ }^\circ\text{C};$  typical values
- (2)  $T_j = 100 \text{ }^\circ\text{C};$  typical values
- (3)  $T_j = 150 \text{ }^\circ\text{C};$  typical values
- (4)  $T_j = 175 \text{ }^\circ\text{C};$  typical values

Fig. 6. Forward current as a function of forward voltage; typical values; per diode

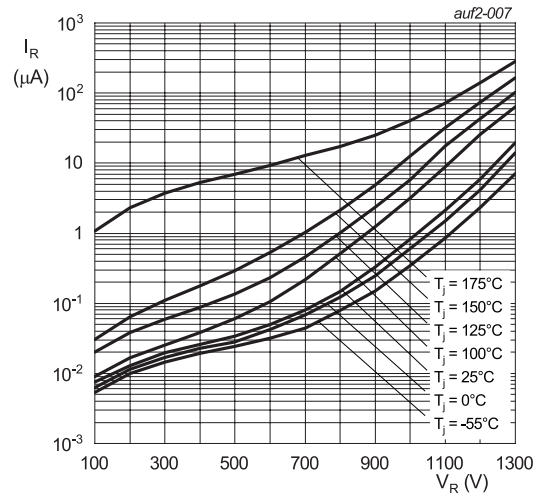
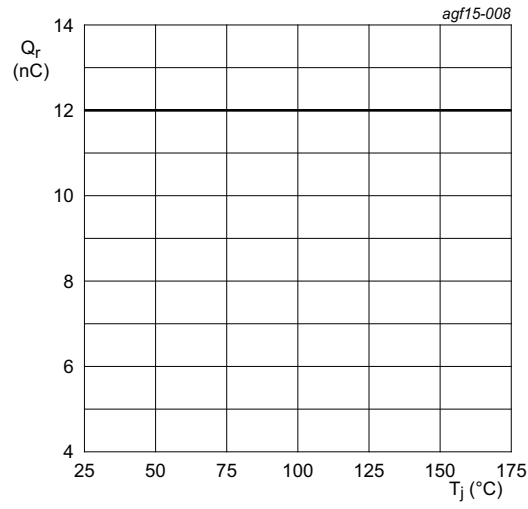

Fig. 7. Reverse leakage current as a function of reverse voltage; typical value; per diode

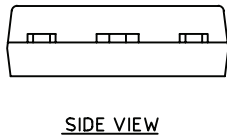
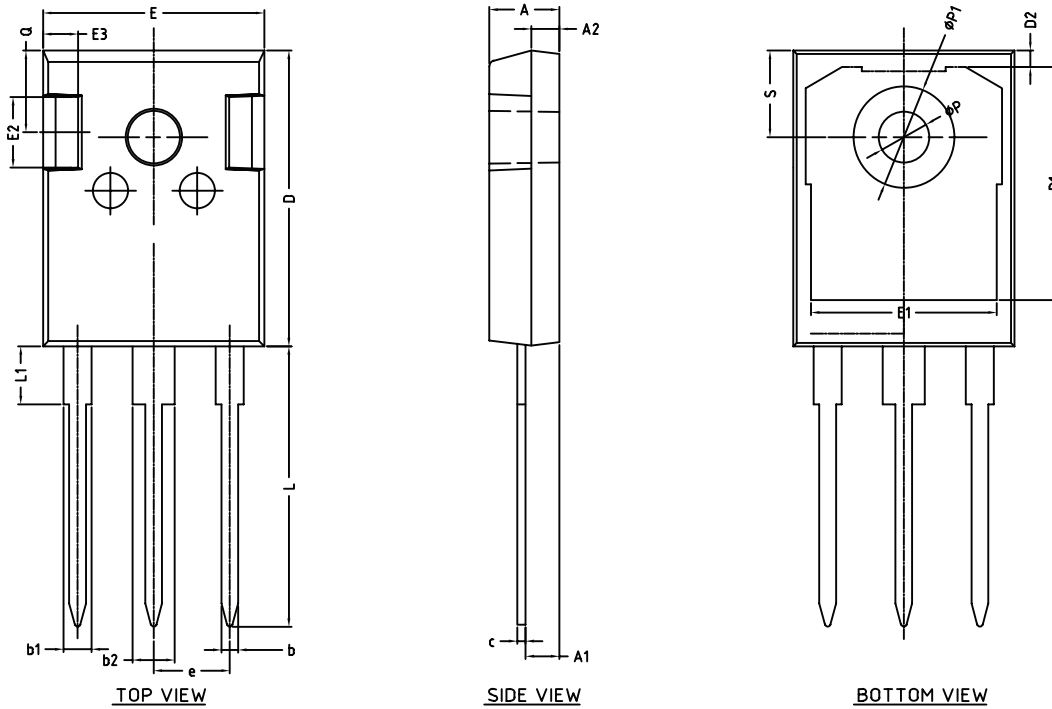

**Fig. 8. Recovered charge as a function of junction temperature; per diode**

### 11. Package outline

Plastic single-ended through-hole package; heatsink mounted; 1 mounting hole; 3-lead TO-247

SOT429N



UNIT	A	A1	A2	b	b1	b2	c	D	D1	D2	E	E1	E2	E3	e	L	L1	P	P1	Q	S	
mm	MAX	5.20	2.60	2.10	1.40	2.20	3.20	0.70	21.10	16.85	1.35	15.90	13.50	5.20	2.60	5.45	20.10	4.75	3.70	7.40	6.00	6.25
	MIN	4.70	2.20	1.90	1.00	1.80	2.80	0.50	20.90	16.25	1.05	15.70	13.10	4.80	2.40	19.80	-	3.50	-	5.60	6.05	

OUTLINE VERSION	REFERENCES			PROJECTION	ISSUE DATE
	IEC	JEDEC	EIAJ		
SOT429N		TO-247			

#### IMPORTANT NOTICE – PLEASE READ CAREFULLY

SZGKT Microelectronics NV and its subsidiaries reserve the right to make changes, corrections, enhancements, modifications, and improvements to SZGKT